

zeparo

Separator Heating and cooling water systems

Zeparo Dirt ZED ... F

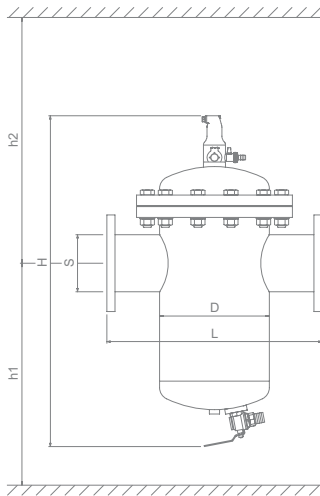

Separator for sludge particles

- helistill separator
- eccentrically arranged de-sludging valve
- Extended type, detachable for the removal of the helistill separator, steel, color beryllium
- addition of antifreeze up to 50%
- pocket for retrofitting optional dry magnet
- Zeparo Top eXtra ZUTX air vent, de-sludging valve and lifting hook included in the delivery for the on-site assembly
- horizontal installation, flange connection PN 16
- constructed according to PED/DEP 97/23/EC

PS: 10 bar TS: 110 °C

Type	D	H	h1	h2	L	G	S	VM	DP _{VM}	Article-Nº
	mm	mm	mm	mm	mm	kg	DN	m ³ /h	bar	
ZED 125 F	324	980	681	1088	635	101	125	147	0.135	782 3125
ZED 150 F	324	980	681	1088	635	104	150	218	0.146	782 3150
ZED 200 F	406	1157	802	1284	775	180	200	360	0.150	782 3200
ZED 250 F	508	1379	985	1485	890	262	250	575	0.155	782 3250
ZED 300 F	610	1646	1125	1745	1005	318	300	814	0.158	782 3300

Zeparo Dirt ZED ... S

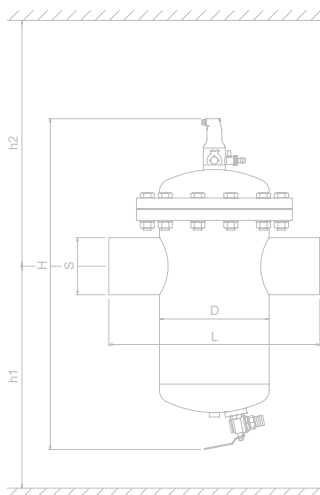

Separator for sludge particles

- helistill separator
- eccentrically arranged de-sludging valve
- Extended type, detachable for the removal of the helistill separator, steel, color beryllium
- addition of antifreeze up to 50%
- pocket for retrofitting optional dry magnet
- Zeparo Top eXtra ZUTX air vent, de-sludging valve and lifting hook included in the delivery for the on-site assembly
- horizontal installation, welding connection
- constructed according to PED/DEP 97/23/EC

PS: 10 bar TS: 110 °C

Type	D	H	h1	h2	L	G	S	VM	DP _{VM}	Article-Nº
	mm	mm	mm	mm	mm	kg	DN	m ³ /h	bar	
ZED 125 S	324	980	681	1088	623	101	125	147	0.135	782 1125
ZED 150 S	324	980	681	1088	623	104	150	218	0.146	782 1150
ZED 200 S	406	1157	802	1284	763	180	200	360	0.150	782 1200
ZED 250 S	508	1379	985	1485	878	262	250	575	0.155	782 1250
ZED 300 S	610	1646	1125	1745	993	318	300	814	0.158	782 1300